

The 'HiMite-20' Transceiver

Parts list

QTY.	Ref. Des.	Component	Description
2	C10,C11	22 pF NPO disk cap	'22'
1	C12	27 pF NPO disk cap	'27'
3	C1,C2,C18	39 pF NPO disk cap	'39'
1	C6	100 pF disk cap	'101'
1	C15	150 pF monolithic cap	'151'
1	C17	180 pF monolithic cap	'181'
1	C16	390 pF monolithic cap	'391'
9	C3,C13,C100,C101,C103,C104,C106-108	.01 uF disk cap	'103M'
1	C4	.022 uF poly cap	'223'
6	C5,C8,C14,C105,C110,C111	.1 uF monolithic cap	'104'
1	C9	3.3 uF electrolytic cap	banded side is negative
3	C7,C102,C112	47 uF electrolytic cap	" " " "
4	D1,D2,D4,D7	1N4148 diode	See sketch re polarity
1	D3	6V Zener diode	in bag-strip
1	D5	5.1V Zener diode	in bag-strip
1	D6	MV1662 varicap diode	Two leads- bands only
1	D8	1N5818 power diode	in bag-strip
1	--	TO-5 heat sink	Black metal 'hat'
4	L1-A,L1-B,L2,L3	4.7 uH RF choke	In bag-strip/ /yellow/viol.
1	L6	3.3 uH RF choke	In bag-strip/orange/org.
1	L4- 1.02 uH: wind w/ 16 turns supplied wire	T37-2 toroid	Red toroid
1	L5- 0.6 uH: wind w/ 14 turns supplied wire	T37-6 toroid	Yellow toroid
1	LED	T1-3/4 LED	Observe 'flat' on drawing
3	Q1,Q2,Q5	2N7000 FET	3 leads- plastic body STATIC SENSITIVE
1	Q3	2N3906 transistor	3 leads- plastic body
1	Q4	2N4401 transistor	3 leads- plastic body
2	Q6,Q7	MPSH10 transistor	3 leads- plastic body
1	Q8	2N5109 transistor	3 leads, metal body
1	R21	5.1 ohm resistor	Green-brn-gold
1	R6	10 ohm resistor	Brown-blk-black
4	R8,R17,R19,R20	100 ohm resistor	Brown-blk-brown
3	R1,R9,R16	1K ohm resistor	Brown-black-red
1	R10	2.2K ohm resistor	Red-red-red
2	R2,R3	10K ohm resistor	Brown-blk-orange
2	R14,R18	22K ohm resistor	Red-red-orange
2	R11,R15	47K ohm resistor	Yellow-violet-orange
2	R7,R13	100K ohm resistor	Brown-blk-yellow
1	R12	330K ohm resistor	Orange-orange-yellow
2	R4,R5	1M ohm resistor	Brown-blk-green
1	U1	SA602AN / SA612AN	8-pin DIP IC
	U2	LM1458	8-pin DIP IC
	U3	12C508A	8-pin DIP IC STATIC SENSITIVE
1	U4	78L08 volt. reg.	3 leads- plastic body
1	--	24" (60cm) #24 wire	
3	--	8-pin IC socket	
1	Y1	14.060 MHz crystal	HC-49/U (metal can)
2	Y2, Y3	14.060 MHz crystal	Metal cylinder

Quantities shaded in grey are in the anti-static bag

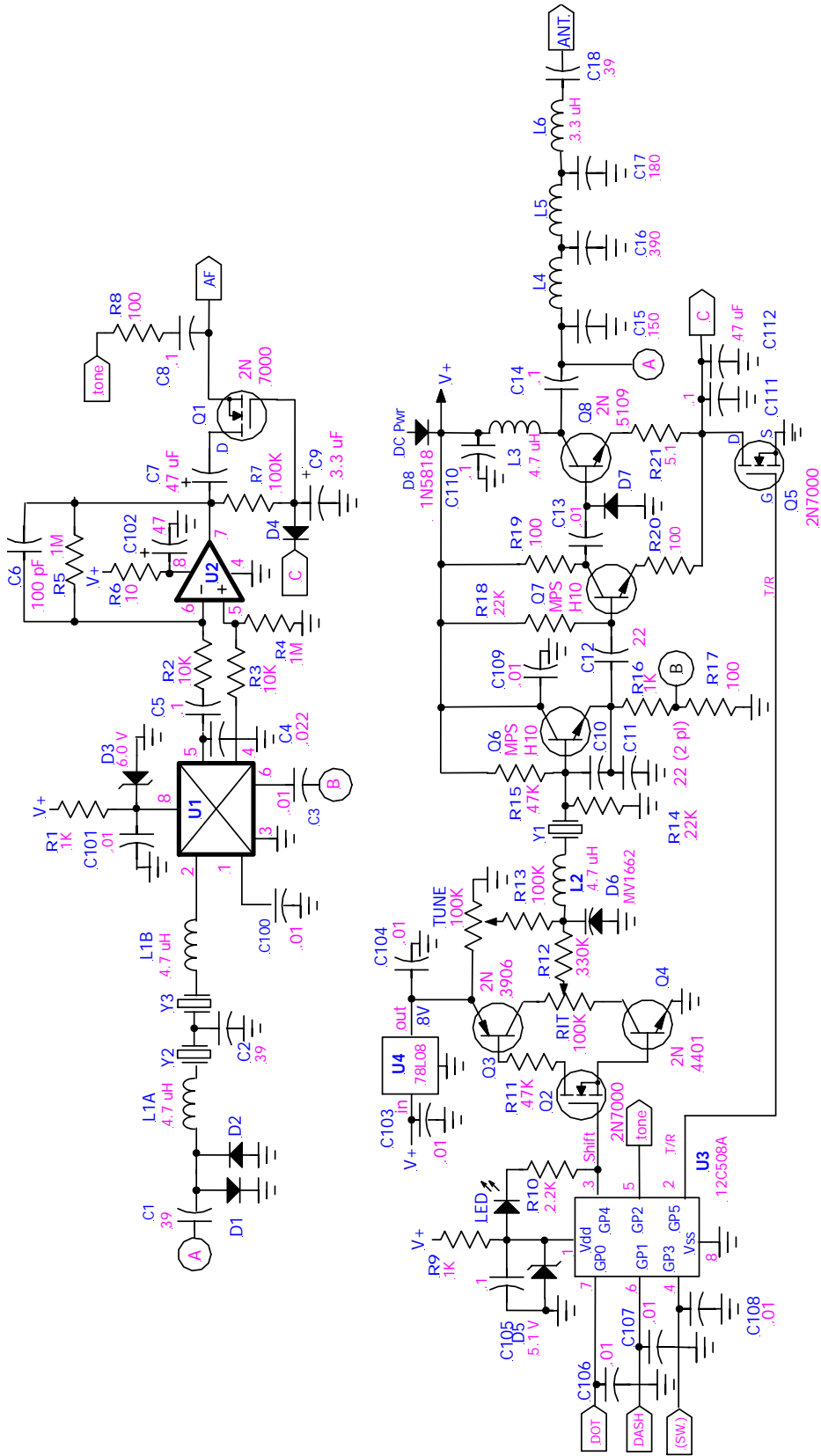

The HiMite-20 Version_2
D. Benson, K1SWL 11/16/2006

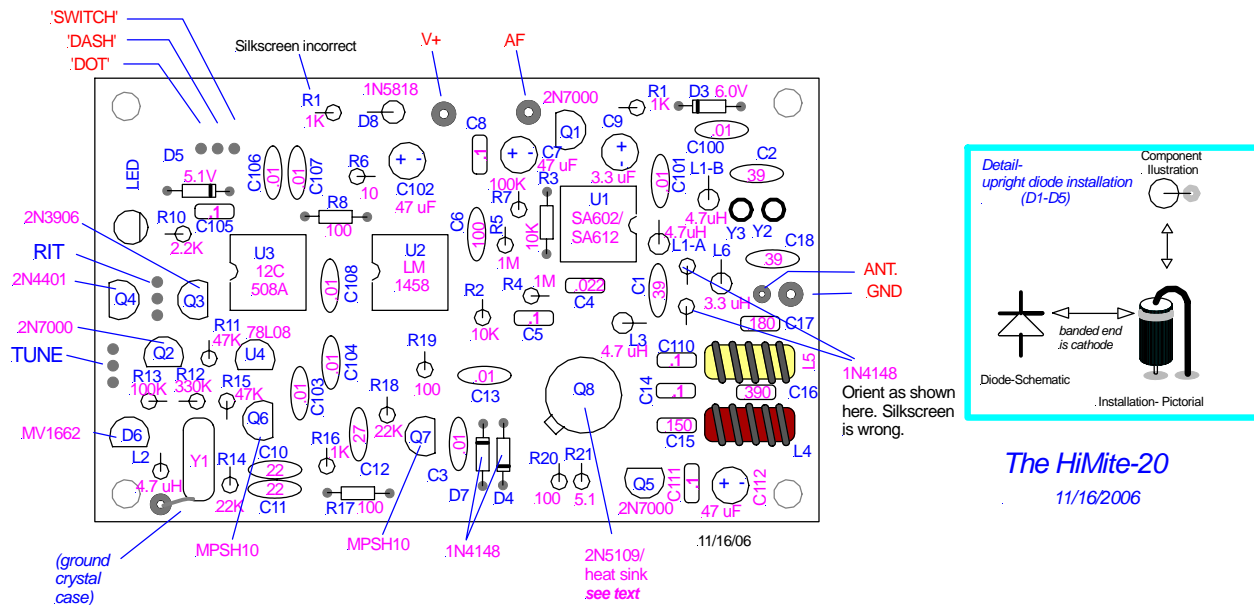

Assembly Notes

- If you're new to kit-building, I recommend downloading the 'RockMite' supplement:

<http://smallwonderlabs.com/RMhelps.pdf>

Please note- the URL is case-sensitive- type it exactly as shown above

- **Resistors and diodes:** Most of the resistors and diodes and the RF chokes are mounted 'hairpin'-fashion. Diodes are orientation-critical- be sure to match the banded end of the diode to the wire bend as shown above at upper right, and follow the installation orientation shown on the pictorial above. Resistors are non-critical- their orientations shown above need not be strictly observed.
- **RF Chokes:** When bending the leads on these devices for upright installation, avoid a sharp radius on the lead-bend. This tends to stress the internal lead attachment and causes 'open-circuit' failures
- **Crystal installation:** Stand Y1 slightly (0.5 to 1mm) above the printed-circuit board to prevent shorts from case to PC-board traces. Install short lengths of leftover resistor lead from the bottom end of the crystal case to the nearest ground point. A spare ground pad is provided next to Y1. [The crystal case is tinned and will accept solder readily- use a minimum of heat.] *You'll find it easiest to stand the wire lead up in its mounting hole and solder it first, then cut the wire short, bend it over to the crystal case and solder that end.*
- **Q8 Installation:** Install the supplied heat sink on the 2N5109 transistor **before installing the transistor on the board.** This will be a very tight fit. I suggest using a slot screwdriver to gently spread the heat sink apart to increase its diameter. Work cautiously, gradually working it apart until the heat sink is a snug slide-fit onto the transistor. A needle-nose pliers is then helpful in seating the sink to full depth on the transistor. Stand Q8 slightly (0.5 to 1mm) above the printed-circuit board.
- **Controls:** A pair of 100K potentiometers is included in this kit for TUNE and RIT functions. A normally-open SPST pushbutton switch is needed for the SWITCH function.
- It may be helpful to note the tight clusters of parts and install those first. Component spacing around the wire connections for the RIT control is quite tight – you may find it helpful to add pot wiring before installing Q3 and Q4. The order of component installation is otherwise non-critical.
- Install ICs in the sockets as shown above. **Note: U1 is installed 'backwards', i.e, notch or dot facing to the right.** *If you inadvertently installed the socket backwards..leave it! No one will ever know.*

HiMite operation:

The HiMite is VXO-tuned. The microcontroller provides a 'shift' signal to the Local Oscillator. This signal changes state upon key-down and key-up and provides approximately a frequency shift determined by the RIT control setting.

The HiMite contains a built-in Iambic Keyer. Dot and Dash inputs are not firmware-reversible but key-jack leads may be reversed to suit the operator's preference.

If either the Dot or Dash inputs is grounded upon power-up, the keyer function is bypassed and the other input accepts a straight-key or external keyer. This is achieved automatically by the use of a 3-conductor jack and 2-conductor (monaural) plug. *Thanks to Steve Weber, KD1JV, for the suggestion.*

'Switch' Input-

- A **brief (<250 ms)** closure to ground on the 'switch' input turns RIT off and on.

Frequency selection:

The 'TUNE' CONTROL IS USED TO ZERO-BEAT OTHER STATIONS. THE 'RIT' CONTROL THEN SETS RECEIVED SIGNALS TO A COMFORTABLE PITCH.

To call another station, depress the switch briefly- the LED will come on. Zero-beat the received signal- this sets your transmit frequency to the other station's. Tap the switch again, the LED turns off. Use the 'RIT' control to re-acquire the other station. When you transmit, the LED lights in time with the key-down signal.

To call CQ: depress the switch to turn the LED on. Use the TUNE control to find a clear spot (if there's a received signal near zero-beat, it's not a clear spot). Depress the switch again to turn RIT on. After sending CQ, use the RIT control to listen for answers to your call.

Confused? Let's try this again- When the LED is off, the RIT control is activated. It'll have an effective tuning range of from 400 to 1500 Hz, depending on where the TUNE control is set. When you go key-down, the LED illuminates and the RIT function is turned off. This maintains a consistent transmit frequency no matter what you do with the RIT control during a QSO.

- A **longer (>250 ms)** closure to ground on the 'switch' input puts the keyer in a speed-adjustment mode. The HiMite outputs a Morse code "S" to acknowledge entry into this mode. Tapping (or holding) the Dot paddle speeds up the keyer; the same operations on the Dash paddle slow it down. The default (power-up) speed is approximately 16 WPM and the upper and lower limits are ~40 WPM/5WPM. If no dot/dash inputs are received over an interval of ~1.5 seconds, the HiMite outputs a lower-frequency tone and reverts to normal operation. *The Morse "S" and subsequent tones are not transmitted on the air.*

Missing parts/ need help? Contact me: dave@smallwonderlabs.com

Dave Benson, K1SWL