

Small Wonder Labs

The *DSW-II-20* Transceiver Kit



Welcome! The DSW-II manual departs from the traditional Small Wonder Labs instructions. These pages contain the information necessary for a reasonably-experienced builder to complete this kit successfully. If you're new to kit-building, please go on-line and check out:

<http://smallwonderlabs.com/DSWhelps.pdf>

That URL contains a Supplement document (in .pdf format) with component identification tips, technical description, basic soldering instruction and troubleshooting information. Why this approach? You've seen most of this information in my earlier manuals- print only the portion you need and save a tree!

This document itself is kept current at http://smallwonderlabs.com/DSW20_Manual.pdf

Table of Contents:

Description	Page
Parts list	2-3
Schematic- Transmitter/Local Oscillator	4
Schematic- Receiver	5
Pictorial Drawing	6
Assembly Instructions	7-9
Alignment	11
Operating the DSW-II	12
Addendum	13

The 'DSW-II-20'

Parts list

(quantities in blue are those items pre-installed by Small Wonder Labs)

Qty.	Ref. Designator	Component	Description
1	C26	6.8 pF NPO disk cap	'6.8' or '6.8J'
2 (2)	C22,C23	22 pF NPO disk cap	'22', <i>Pre-installed</i>
3	C1,C2,C17	27 pF NPO disk cap	'27' or '27J'
1	C4	33 pF NPO disk cap	'33', '33J' or '330'
2	C24,C27	33 pF NPO monolithic cap	'330'
1	C5	47 pF NPO disk cap	'47' or '47J'
1	C25	68 pF NPO monolithic cap	'680'
1	C12	15-70 pF trimmer cap	<i>Brown</i>
8	C6-C11, C16, C104	150 pF disk cap	'151' or '151J'
1	C35	150 pF NPO monolithic cap	'151' or '151J'
2	C32, C34	330 pF NPO monolithic cap	'331' or '331J'
1	C33	470 pF NPO monolithic cap	'471' or '471J'
1	C19	820 pF poly cap	'821' or 821J'
1	C20	2200 pF (.0022 uF) poly cap	'222' or '222J'
14	C3,C15,C28-30,C101-102, C108-111,C118,121,122	.01 uF disk cap	'103', ceramic
2 (2)	C114,C115	.01 uF 0805 SMT cap	<i>Pre-installed</i>
2	C14,C18	.033 uF poly cap	333' or '333K'
7 (1)	C13,C31,C103,C106, C107,116,C120	.1 uF monolithic cap	'104', epoxy case
2 (2)	C112,C113	.1 uF 1206 SMT cap	<i>Pre-installed</i>
1	C117	10 uF electrolytic cap	
2	C21,C105	47 uF electrolytic cap	
1	C119	220 uF electrolytic cap	
7	D1-D6,D8	1N4148 diode	<i>glass body</i>
1	D7	1N5818 diode	
1	D9	1N4751A diode	
1	HS1	TO-220 heat sink	<i>Black-anodized w/fins</i>
1	--	#4-40 x 1/4" machine screw	
1	--	#4-40 nut	
2	J1,J4	3.5mm stereo conn, PC-mount	<i>w/ knurled nut</i>
1	J2	DC power jack, 2.1/5.5mm	
1	J3	BNC conn., PC-mount	<i>w/ nut, lock washer</i>
1	J5	10-pin header strip	
1	L1	30 t. #26 mag. wire on T44-2	Red core, larger
1	L2	6.8 uH RF choke	Blue-grey-gold
1	L3	22 uH RF choke	Red-red-black
1	L4	3.3 uH SMT Inductor	
1	L5	2.7 uH SMT Inductor	
1	L6	1 uH SMT Inductor	
1	L7	FT37-61 toroid, wind 10 turns	dark grey toroid
1	L8	T37-2, wind w/ 10 turns	red toroid
2	L9, L10	T37-6, wind w/ 15 turns	yellow toroid
1	P1	2.1mm/5.5mm power plug	
1	--	2' (0.7m) power wire	

2	R7, R14	10 ohm, 1/4W 5% resistor	Brown-blk-blk
2	R2,R22	51 ohm, 1/4W 5% resistor	Green-brwn-blk
1	R26	100 ohm, " " "	Brown-blk-brown
1 (1)	R17	240 ohm, <i>pre-installed</i>	Red-yellow-brown
3	R1,R18, R23	470 ohm, 1/4W 5% resistor	Yellow-violet-brn
1	R19	500 ohm trim pot	Blue plastic, 3 leads
1 (1)	R16	3.9K ohm, SMT res., 0805	<i>pre-installed</i>
6	R3,R4,R15,R20-21, R25	10K ohm, 1/4W 5% resistor	Brown-blk-orange
2	R10,R24	22K ohm " " "	Red-red-orange
3	R5,R6,R11	510K ohm " " "	Green-brn-yellow
3	R8,R12,R13	1M ohm " " "	Brown-blk-green
1	R9	4.7 M resistor	Yellow-violet-green
1	T1	IF Transformer	<i>Internal Cap removed</i>
1	Q1	2N5485 or 2N5486 transistor	(TO-92 package)
2	Q2,Q3	2N7000 transistor	(TO-92 package)
1	Q4	2N3906 transistor	(TO-92 package)
1	Q5	2SC1971 transistor	TO-220 package
2	U1,U2	SA602AN or SA612AN IC	8-pin DIP IC
1	U3	TS922 IC, Audio Amplifier	8-pin DIP IC
1 (1)	U4	78L05A	<i>pre-installed</i>
1 (1)	U5	50.000 Mhz Oscillator	<i>pre-installed</i>
1 (1)	U6	AD9835BRU, DDS IC	<i>pre-installed</i>
1 (1)	U7	PIC16C622A microcontroller, preprogrammed	<i>pre-installed</i>
1	U8	LT1252 IC, video driver IC	8-pin DIP IC
1	U9	78L06A	TO-92 package
4	Y1-Y4	5.185 Mhz crystal, series res.	<i>matched set, '5.18'</i>
1 (1)	Y5	4.096 Mhz crystal, 20 pF	<i>pre-installed</i>
4	--	8-pin IC socket	
1 (1)	--	18-pin IC socket	<i>pre-installed</i>
1		4' (1.2m) #24 magnet wire	
1	--	2' (60 cm) #26 magnet wire	
1	--	Printed circuit board	'SWL 7/15/02'
1	--	Enclosure, w/ 2-bezels, 4- black-anodized screws	
1	--	Front panel	
1	--	Rear panel	
1	--	Small knob	
1	--	Medium knob	

Notes: 1) Items with gray-shaded quantities are in an anti-static envelope.

Front-Panel Daughterboard

2	C1,C2	.01 uF disk cap	'103' or '103M'
1	POT	5K ohm, 9mm PC-mount	/ DK P3C3502
1	S1	Subminiature pushbutton sw.	/ w/ nut, lockwasher
1	S2	Subminiature. toggle sw.	/ DK CKN1088
1	S3	Shaft encoder, rotary	3 leads, w/ nut, washer
1	--	Printed circuit board	
1	LED	Green LED	
1	W1	Flex cable	/ DK A9BAG-1002F
3	R1-R3	1.5K ohm, 1/4W 5% resistor	Brown-green-red

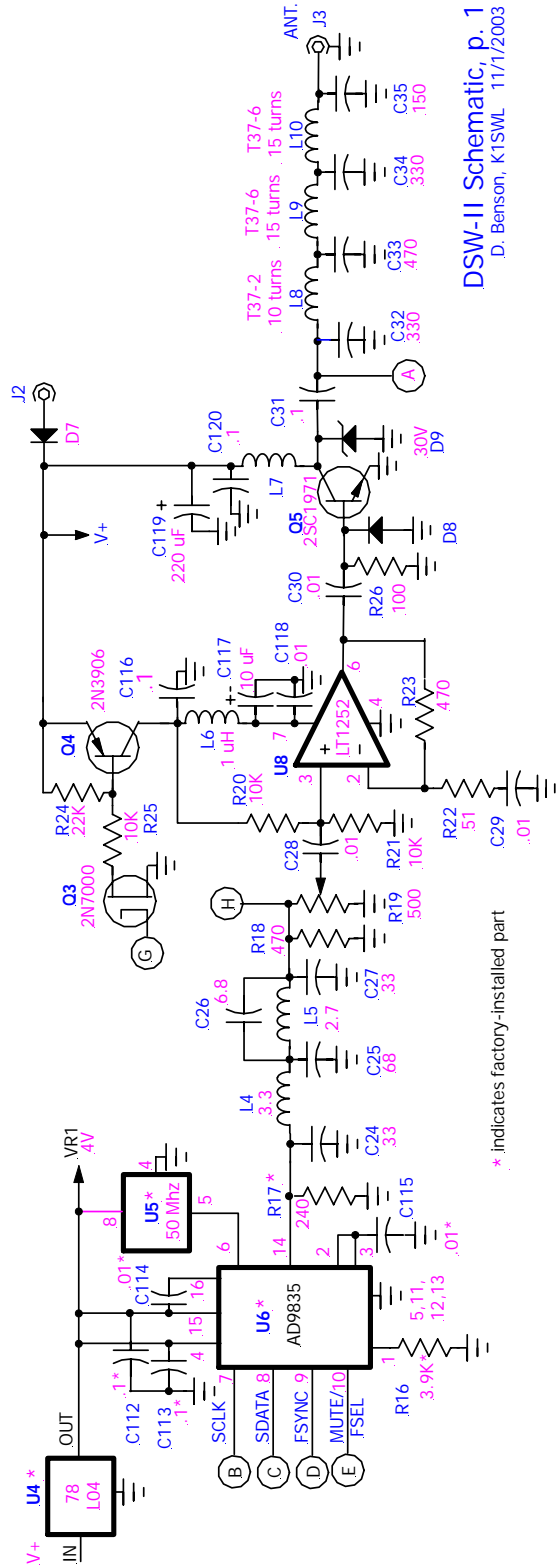
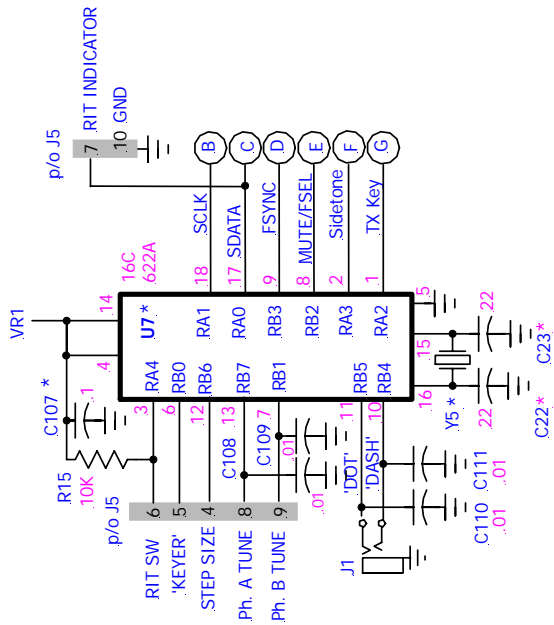
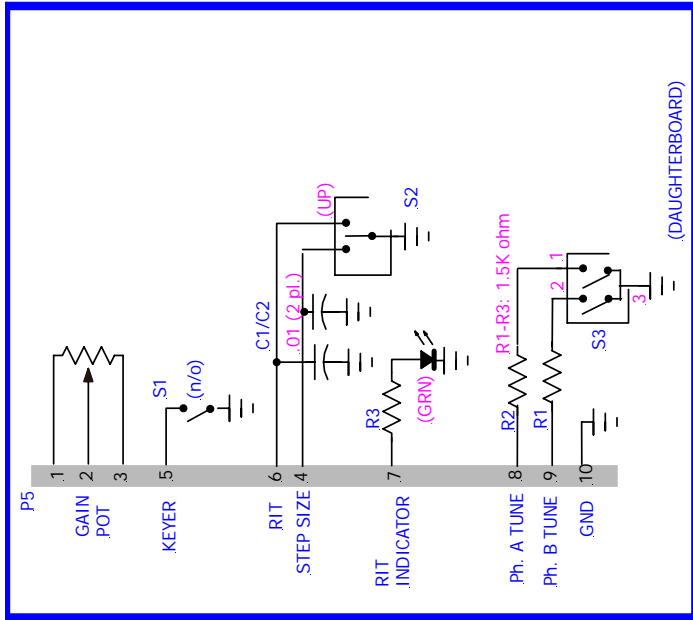

* indicates factory-installed part

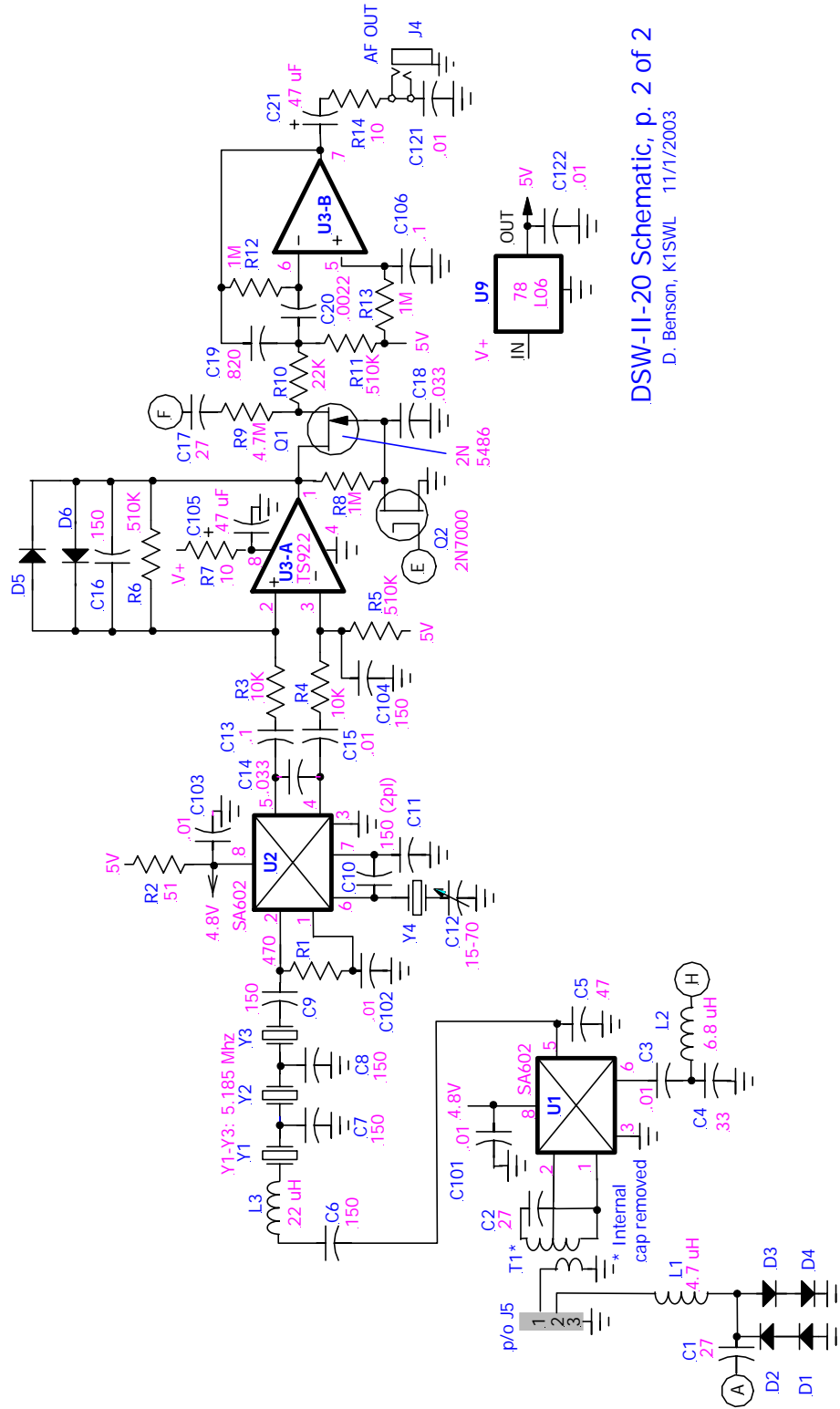

DSW-II-20 Schematic, p. 2 of 2
 D. Benson, K1SWL 11/1/2003

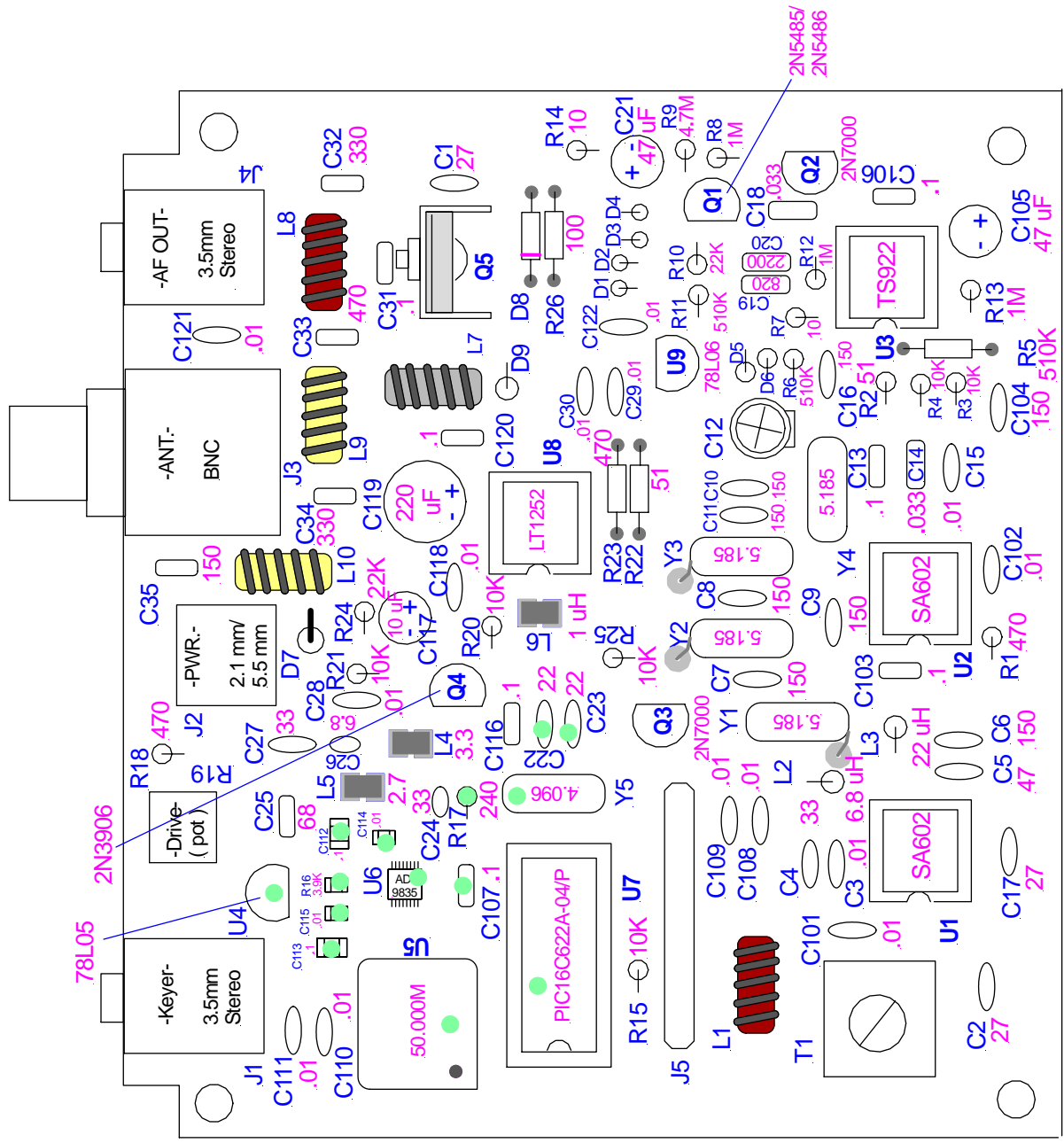

DSW-II-20 - Pictorial
 Dave Benson, K1SWL
 as of 12/16/2003

Note: Components with green dots are pre-installed by Small Wonder Labs.

Assembling the DSW-II-20

The assembly steps on the following pages are suggested only- they're by no means the only possible assembly sequence- Assembly starts with the local oscillator (upper left corner) and installs components from left to right across the board.

As you proceed through the assembly, each component is installed, soldered, and the leads clipped short on the underside of the board. *I recommend adding 3-4 components between soldering steps- add too many at a time and you may overlook making solder connections! Solder only on the bottom side of the board unless the instructions indicate otherwise- the board holes are all plated-though.*

Most resistors and diodes are installed upright, i.e., bent in 'hairpin' fashion. Check the pictorial and/or board silkscreen for guidance.

"Big-Boy Corner"

This is for those of you who don't feel the need to follow instructions:

- [Surface mount components L4-L6 should be installed early on- they're more difficult to install when surrounded by taller components.]
- Crystals should be stood slightly (0.5 to 1mm) above the printed-circuit board to prevent shorts from the crystal cases to any top-side traces.
- Diode Installation:

Some of the diodes are bent for "upright" installation on the board. Installation polarity is as shown below. Be sure to note the orientation of the silkscreened circle on the board and install the diode body over this hole. The cathode (banded) end of the diode is oriented at the top. For diodes which are installed 'lying down', match the banded end to that shown on the silkscreen

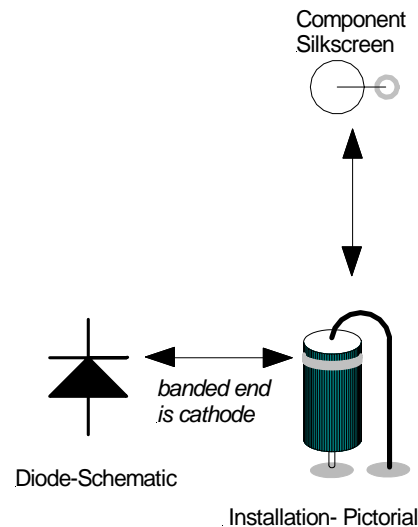

Main Board:

Recommended assembly sequence:

- 1) C24- 33 pF monolithic cap
- 2) Install surface-mount inductor L5 (2.7 uH.). *Note: the inductor itself is inside a black plastic carrier. **Pre-tin the inductor pads on the PC board sparingly with solder before installing the part.** Place this component on the two pad locations and restrain carefully in place with tweezers. Tack one end down with the soldering iron, solder the other end sparingly, and retouch the end originally tacked down. **Good component alignment is important to ensure that there are no short-circuits- check your work carefully for solder bridges.***
- 3) L4- 3.3 uH SMT inductor (see instructions above).
- 4) C26- 6.8 pF disk cap
- 5) C25- 68 pF monolithic cap
- 6) C27- 33 pF monolithic cap
- 7) R18- 470 ohm resistor (ylw-violet-brn)
- 8) R19- 500 ohm pot (blue/ 3 leads)
- 9) C28- .01 disk cap
- 10) C110- .01 disk cap
- 11) C111- .01 disk cap
- 12) C116- .1 uF monolithic cap

- 13) D7- 1N5818. Install this part as shown on the pictorial drawing.
- 14) J2- DC power jack. Once one pin on this jack has been soldered into place, ensure that the jack is aligned at right angles to the board edge and seated firmly before soldering the remaining pins.
- 15) J1- 3.5 mm stereo connector.
- 16) R15- 10K resistor (brn-blk-orange)
- 17) J5- 10-pin header strip. Solder one pin and ensure that the component is firmly seated on the board and upright before soldering remaining pins.
- 18) L1- Using the 24" (60 cm) length of the thinner (#26) magnet wire. Wind **30** turns on a T44-2 core (the **larger** red toroid).
 [Each time the wire passes through the center hole, it counts as a turn. See the DSW Supplement for further discussion.] Trim the excess wire leads to a length of 3/8" (1 cm) and gently scrape the insulation off the wire ends using a hobby knife or other sharp blade.
Caution: don't assume your soldering iron will melt the wire insulation off- it probably won't! Failure to strip the lead ends adequately (or at all) is one of the most common difficulties we find when troubleshooting a returned unit.
 (Install L1)
- 19) C101- .01 disk cap
- 20) C109- .01 disk cap
- 21) C108- .01 disk cap
- 22) C4- 33 pF disk cap
- 23) C3- .01 disk cap
- 24) T1 (IF transformer) Note: check the recess on the underside of this component- ensure that the tubular cap has already been removed, and if not, remove it.
- 25) C2- 27 pF disk cap
- 26) U1 socket- Orient with the notched end of the socket matching that of the board silkscreen.
- 27) C17- 27 pF disk cap
- 28) Y1- 5.185 MHz crystal.
 Install this component slightly above the board (0.5 to 1 mm) to prevent the case from shorting to board traces. Using a leftover component lead, install a jumper from the pad below and to the left of Y1 (see pictorial.) The easiest way to do this is to set the board down, stand the wire piece upright and soldering on the top side of the board. Trim to 3-4mm (1/8"+), bend the lead over and solder to the crystal can. Use a minimum of heat. *The crystal case will accept solder readily.*
- 29) L2- 6.8 uH RF choke
- 30) L3- 22 uH RF choke
- 31) C5- 47 pF disk cap
- 32) C6- 150 pF disk cap
- 33) C7- 150 pF disk cap
- 34) C8- 150 pF disk cap
- 35) C9- 150 pF disk cap
- 36) C103- .1 uF monolithic cap
- 37) U2 socket - Orient with the notched end of the socket matching that of the board silkscreen.
- 38) R1- 470 ohm resistor (ylw-violet-brn)
- 39) C102- .01 uF disk cap
- 40) C11- 150 pF disk cap
- 41) C10- 150 pF disk cap
- 42) L6- 1 uH SMT inductor
- 43) **Q3- 2N7000- this part is static-sensitive.**
- 44) Y2- 5.185MHz crystal. Install as per step 28, add case ground connection (see pictorial).
- 45) R25- 10K resistor (brn-blk-orange)
- 46) Y3- 5.185 MHz crystal. Install as per step 28, add case ground connection (see pictorial).
- 47) C12- 15-70 pF trimmer cap.
- 48) Y4- 5.185MHz crystal. Install as per step 28. **Note:** Do not install a ground lead for this case.
- 49) C13- .1 uF monolithic cap
- 50) C14- .033 uF poly cap
- 51) C15- .01 disk cap
- 52) R21- 10K resistor (brn-blk-orange)
- 53) R24- 22K resistor (red-red-orange)

- 54) Q4- 2N3906- Orient the flat side of this device to match that of the pictorial and silkscreen.
- 55) R20 - 10K resistor (brn-blk-orange)
- 56) C117- 10 uF electrolytic cap. *This part is polarity- sensitive.* Install the longer wire lead on the '+' side of the component silkscreen. The black band on the component case denotes the negative or '-' side.
- 57) C118- .01 disk cap
- 58) R22- 51 ohm resistor (grn-brown-blk)
- 59) R23 - 470 ohm resistor (ylw-violet-brn)
- 60) U8 socket- Orient with the notched end of the socket matching that of the board silkscreen.
- 61) C119- 220 uF electrolytic cap. *This part is polarity- sensitive.*
- 62) C120 - .1 uF monolithic cap
- 63) C29- .01 disk cap
- 64) C30- .01 disk cap
- 65) U9- 78L06 IC (3 leads) Orient the flat side of this device to match that of the pictorial and silkscreen.
- 66) C122 - .01 disk cap
- 67) D5- 1N4148. *This part is polarity- sensitive.* see the sketch on page 7.
- 68) D6- 1N4148. *This part is polarity- sensitive.*
- 69) R6- 510K resistor (grn-brn-yellow)
- 70) C16- 150 pF disk cap
- 71) R2- 51 ohm resistor (grn-brn-blk)
- 72) R4- 10K resistor (brn-blk-orange)
- 73) R3- 10K resistor (brn-blk-orange)
- 74) C104- 150 pF disk cap
- 75) R5- 510K resistor (grn-brn-yellow)
- 76) U3 socket- Orient with the notched end of the socket matching that of the board silkscreen.
- 77) R13- 1M resistor (brn-blk-green)
- 78) C105- 47 uF electrolytic cap. *This part is polarity- sensitive.*
- 79) C106- .1 uF monolithic cap
- 80) R7- 10 ohm resistor (brn-black-black)
- 81) R12- 1M resistor (brn-blk-green)
- 82) C19- 820 pF poly cap
- 83) C20- .0022 uF poly cap
- 84) C18- .033 uF poly cap
- 85) **Q2- 2N7000** This part is static-sensitive
- 86) R11- 510K resistor (grn-brn-yellow)
- 87) R10- 22K resistor (red-red-orange)
- 88) Q1- 2N5485/6 Orient the flat side of this device to match that of the pictorial and silkscreen.
- 89) R8- 1M resistor. (brn-blk-green)
- 90) R9- 4.7M resistor (ylw-violet-green)
- 91) D1-D4. *These parts are polarity- sensitive.*
- 92) C21- 47 uF electrolytic cap. *This part is polarity- sensitive.*
- 93) R14- 10 ohm resistor (brn-black-black)
- 94) R26- 100 ohm resistor (brn-black-brown)
- 95) D8- 1N4148 *This part is polarity- sensitive.*
- 96) D9- 1N4751A *This part is polarity- sensitive.*
- 97) L7- Cut a **7"** (18 cm) length of the supplied magnet wire. Wind **10** turns on an **FT37-61** (grey) toroid.
- 98) C34- 330 pF monolithic cap
- 99) C35- 150 pF monolithic cap
- 100) L10- Cut a **10"** (25 cm) length of the supplied magnet wire. Wind **15** turns on an **T37-6** (**yellow**) toroid.. Prepare leads as described earlier and install/
- 101) C33- 470 pF monolithic cap
- 102) C32- 330 pF monolithic cap
- 103) L9- Cut a **10"** (25 cm) length of the supplied magnet wire. Wind **15** turns on an **T37-6** (**yellow**) toroid.. Prepare leads as described earlier and install.
- 104) C31- .1 uF monolithic cap
- 105) L8- Cut a 7" (18 cm) length of the supplied magnet wire. Wind 10 turns on the T37-2 (**red**) toroid.. Prepare leads as described earlier and install.
- 106) C121- .01 disk cap
- 107) Install Q5 in an upright position. **Make sure that the integral metal tab on this device faces toward the rear of the board** (i.e., towards the connectors).
- Using the supplied machine screw and nut, affix the heat sink (finned, black-metal) to the metal tab on the transistor. Select the heat-sink orientation which results in the lower vertical height above the board. Ensure that

the heat sink is lined up vertically and tighten the hardware.

'Thermal compound' is not needed.

- 108) C1- 27 pF disk cap
- 109) J3- BNC connector. Seat firmly, solder all pins.
- 110) J4- 3.5 mm stereo connector
- 111) Install the four DIP (Dual-in-Line package) ICs at the locations shown on the pictorial. The components are polarity-sensitive- make sure the 'dot' or 'notch' on each IC is oriented to match the notched end of each socket. [As supplied, the IC leads are usually spread too far apart to allow easy insertion into the sockets. Simply press each row of IC leads gently down on a tabletop to reduce the spacing between the two rows of leads.]

Daughterboard/ Front Panel Assembly:

[The daughterboard is the 1"x3.5" PC board which the front panel controls mount on.]

- ***Do not install the LED until instructed to.***

- 1) Remove- and set aside- any nuts and lock washers from the front panel controls.
- 2) Using a pair of diagonal cutters, snip 5/16" (7mm) off the plastic shaft of the 5K gain pot. Install the pot firmly on the board and solder.
- 3) Install R1-R3 (1.5K ohm) and C1,C2 (.01 uF)
- 4) **Flex cable W1:**

The 10-pin flex cable is installed from the rear (solder) side of the daughterboard. **The pins must protrude through the front of the daughterboard and are soldered on the front side only.** *Solder only one or two pins and ensure that the cable exits at right angles to the daughterboard before proceeding to solder the rest of the pins.*

- 5) Install the subminiature pushbutton switch at S1. **Do not solder this part in place yet.**
- 6) Install the subminiature toggle switch at S2. *This part may be installed without regard to 'up/down'*

orientation- either way's fine. Do not solder this part in place yet.

- 7) Install the rotary shaft encoder at S3. Ensure that this part is firmly and evenly seated on the board. **Do not solder this part in place yet.**
- 8) Install the front panel over the controls and secure the keyer and RIT switch hardware. *Note: if a large flat-washer is supplied with the RIT switch, discard it.*
- 9) *Solder all remaining connections (Keyer switch, RIT switch and shaft encoder)*
- 10) Install lock washers and nuts for the Keyer switch and RIT switch. *A small vise-grip pliers is recommended- take care to avoid scratching the front panel surface.*
- 11) Install and secure the lockwasher and nut for the shaft encoder. **Hand-tighten only.**
- 12) Install the LED. Make sure the longer LED lead goes in the right-hand hole (viewed from the front). This places the 'flat' side of the LED plastic housing on the left - toward the RIT switch. Press-fit the LED until it seats completely on the front panel- it will be quite snug. Solder in place.
- 13) Install and secure the small knob on the gain control pot shaft. *It's a matter of personal taste, of course, but I orient the knob so it covers a '7 o'clock' to '5 o'clock' rotation range. There's some 'slop' in the knob-to-shaft fit due to the difference in diameters- the shaft is 6mm (0.236") while the knob-hole is ~ .250". A 1/4" x 5/8" (6mm x 15mm) strip of paper inserted into the knob-hole prior to installation improves the fit considerably.*
- 14) Install and secure the larger knob on the shaft encoder shaft.

You must perform alignment on the DSW-II prior to final assembly of the enclosure. No test equipment is needed for alignment.

Alignment:

- 1) Plug the flex cable into J5, plug in headphones and 50-ohm nominal antenna, and apply power. The receiver should be alive at this point. Advance the gain control to maximum. Rotate the (dangling) front panel assembly upward and using a slot screwdriver, adjust transformer **T1** for maximum received signal.

2) C12 Adjustment

Description: The IF offset between Transmit and Receive is fixed in the DSW-II's firmware. Because the BFO frequency can vary from unit to unit (crystal and other component tolerances), this adjustment provides a way to adjust the BFO. This ensures that you're answering other stations on a frequency matching theirs. This procedure needs to be performed only once.

- Remove power and plug in keyer paddles or straight key.
- Depress and hold the keyer control switch and reapply power while doing so. (Once power has been applied you may release the switch.) The DSW-II will yield a steady beat note in the headphones.
- Grounding either of the keyer inputs will yield an 800 Hz sidetone.
- Release the keyer input and adjust C12 until the beat note pitch matches that of the sidetone. You may tap the keyer / straight key inputs as needed to repeat until the tones match.
- **Remove DC power.** This causes the DSW-II to exit the calibration mode.

Alternate C12 adjustment procedure:

Powering up the DSW-II with the keyer control switch depressed yields a loud audio tone. This tone may be adjusted to 800 Hz using Spectrogram or DigiPan software and your computer sound card. [DigiPan: select Configure... Band... and click on "Tone".

Spectrogram: www.visualizationsoftware.com

DigiPan: see <http://psk31.com> , software links

Final Assembly:

1. Slide the two enclosure halves apart.
2. Slide a plastic bezel (grey) over the flex cable. The deeper recess is oriented forward so that the front panel is surrounded by the bezel. Using a small Phillips screwdriver, secure the front panel firmly to the enclosure base using 2 of the supplied black-anodized self-tapping screws. *Line up the holes in the bezel with those in the front panel before fastening.*
3. Slide the circuit board assembly into the grooved guides in the aluminum enclosure base. Plug the flex cable into J5 and seat firmly.
4. Remove - and set aside- fastening hardware for all rear-panel connectors.
5. Slide the enclosure top cover into the grooves on the enclosure base- slide fully forward
6. Put the remaining grey plastic bezel in place (*screw holes oriented down*)- do not fasten.
7. Install the rear panel over the connectors and seat. This may be a snug fit - you can use the BNC connector barrel as a 'handle' while you perform this step.
8. Secure the rear panel & bezel firmly to the enclosure using the remaining 2 black-anodized screws.
9. Install and secure the rear panel hardware- knurled nuts for the 'AF out' and 'Key' jacks and lockwasher and hex nut for the BNC connector.

/ A small vise-grips pliers is suggested for tightening this hardware. Take care to avoid scratching the anodized finish.

Do you do a lot of kitbuilding or homebrewing? There's a specialty tool for installing the knurled nuts for the 1/8" (3.5mm) jacks. It's supplied by Mouser Electronics [tel. 800-346-6873] or www.mouser.com ; it's their part number 382-0006

Operating the DSW-II-20

DSW-II functional changes are in this color

Tuning Control

The DSW-II powers up in the Coarse tuning mode. Each step of the rotary shaft encoder yields a 200 Hz frequency step. The shaft encoder has 24 steps/revolution for a tuning rate of 4.8 KHz/turn.

Note: The front panel LED flashes briefly with each tuning step. This is because the LED drive signal is functionally shared with the DDS data signal. This was necessary because the microcontroller pinout was already fully used before this new function was added.

Fine tuning selection:

Pushing and holding the **RIT/Freq** toggle switch **down** causes the tuning control to change to 50 Hz/step. This is annunciated with a two-tone 'bee-boop'. Repeating this operation causes the tuning control to revert to the coarser 200 Hz/step rate; this is annunciated with a two-tone 'boo-beep'.

Initialization:

The DSW-II-20 operating frequency is set to 14060.0 KHz upon power-up. *If the RIT switch is held in the 'up' position during power-up, the operating frequency is instead set to 15.000 MHz. This feature allows reception of WWV for time and propagation info.*

Band Coverage:

The DSW-II is continuously tuned, there are no limit stops on either Transmit or Receive. Some falloff in receive sensitivity will be seen as the DSW-II is tuned more than several hundred KHz from the frequency at which you've peaked the receiver (T1 adjustment). Transmitter response is essentially flat across the 20M band.

Receiver Incremental Tune (RIT)

Pressing the RIT/Freq switch upward turns on RIT, and the front-panel LED illuminates. Pressing the switch upward again turns off RIT and extinguishes the LED. When RIT is ON, the tuning control affects frequency in 50 Hz steps. The transmit frequency does not change when RIT is ON, and frequency readout remains frozen as well. Turning RIT off restores the receive frequency to the value it had before RIT was turned on. Note- the

RIT is volatile; when RIT is re-engaged, it starts over with no offset. The RIT excursion is unlimited.

Frequency Readout

The DSW-II annunciates operating frequency in 3-digit KHz (Morse audio) form when the RIT/Freq is momentarily pressed down. If the first digit is a '0', it will be suppressed, forming a 2-digit readout instead. The frequency readout is output at a rate which matches the keyer speed setting. The default (power-up) speed is 20 WPM.

Sidetone:

The DSW-II uses a fixed 800 Hz audio sidetone.

Iambic Keyer Control

Depressing and releasing the keyer control switch yields an audio Morse sequence of character, each separated by approximately 1.5 seconds. The keyer control sequence is:

"S R T SK"

Keyer control functions are described as follows:

"S" (Speed):

Closing the 'Dot' keyer paddle input increases keyer speed; closing the Dash paddle input decreases it. Once no inputs have been received within 1.5 seconds, the DSW-II sends a "bee-boop" sequence and returns to normal operation. If no paddle closures are detected within the original 1.5 second interval, the keyer control sequence proceeds to the next step. The transmitter is not activated when speed is being adjusted. The 'Dot' and 'Dash' conventions are affected by the 'reverse' function (next paragraph).

The default (power-up) keyer speed is **20 WPM**.

- Minimum keyer speed is 5 WPM
- Maximum keyer speed is 50 WPM

When the min. and max. speeds are reached; this is annunciated by a 'boop' (slow limit) or 'beep' (fast limit).

"R" (Reverse)

If either of the paddles is tapped within 1.5 seconds of the Morse 'R', the dot and dash paddle functions are transposed. If this closure occurs, the DSW-II sends a 'bee-boop' and returns to normal operation. Repeating this operation on a subsequent keyer control sequence causes the Reverse function to toggle (change to the opposite state).

"T" (Tune)

If either of the paddles is tapped within 1.5 seconds of the Morse 'T', the transmitter and sidetone are activated. The transmitter output is a steady full-power carrier, useful for adjusting an antenna tuner or making power measurements. Tapping either of the paddles again causes the DSW-II to exit 'Tune' mode, issue a 'bee-boop' tone sequence and return to normal operation. Note that if the paddle input is held closed, 'Tune' mode aborts after approximately 0.3 seconds.

"SK" (Straight Key)

If either of the paddles is tapped (or their respective input lines grounded) within 1.5 seconds, the DSW-II uses either input as the keying source. This allows the use of a straight key, external keyer or other keying source such as a computer. To revert to the internal keyer after Straight Key mode has been selected, repeat the Keyer control sequence via the front panel switch and respond to the 'SK' prompt- this mode toggles and off.

TX Power Output

Transmitter Power Output is adjustable. The 'Drive' pot on the rear panel may be adjusted to furnish between approximately 0.1W and 4W of RF output.

Addendum:

Missing Parts : dave@smallwonderlabs.com

Please- tell me what the part is, and include your mailing address the first time. A reference designator (e.g., 'C29') is less helpful than a description- I have to look it up, increasing the chances of an error here!

Instruction errors: *Please bring them to my attention at the above e-mail address. In the event of a conflict, the schematic has the highest precedence, followed by the pictorial, then the parts list.*

Comments and suggestions: *ditto- always welcome. That's how products improve!*

Troubleshooting: This information is included in the Supplement document, see the front page of this Instructions document for the Supplement URL. Factory troubleshooting will be available once production starts.

Revisions:

3/28/03: J5 was '17-pin', now 10-pin, added missing T1 (IF-Transformer)

5/6/03- numerous revisions to incorporate feedback from beta-builders.

5/21/ added note describing LED flicker.

5/24- expanded details in assembly steps

5/28- corrected schematic, P/L- C12 is 70 pF

6/5 - Revised R23 to 470 ohms for smoother power adjustment. Miscellaneous typo corrections

6/11- Revised markings for 33, 68 pF mono caps; U4 = 78L05

6/13- reinstalled C32, revised turns count, core material for L8. Affects pp. 2,4,6,9

7/16- revised TOC, fixed wrong colors L8/L10, extensively revised daughterboard/ front panel assembly to reduce alignment stress on controls.

9/10- changed U9 (was 78L05) to 78L06 following several reports of 'thump'. Affects pp. 4-6,9

9/25- revised appearance of L7 (p.6)

11/1- Daughterboard: P5 pins 4,6 transposed, switch 'S3' ground is now pin 3

12/16- revised throughout to reflect new L1 (toroid), drive control now correct, silkscreen cleanups.